

40-30 SL

Full Range Multi Room Speaker

Features:

- Symmetrically Controlled Beamwidth
- Configured as mono or stereo speaker
- Very low distortion
- Very low power consumption
- Wide frequency response 40Hz to 40kHz
- Fast, easy and simple installation
- Suitable for a wide range of application, from small HiFi Systems, Hotels and other general public spaces, configured as a single stereo speaker or as multiple mono speakers
- Ultra-slim aesthetically pleasing cabinet design.

40-30 SL Overview:

This multi purpose monitor shares many characteristics with the other models in the SL range. Maintaining Artcoustic's clean contemporary design.

The '40-30 SL' is a unique addition to the Artcoustic range. It serves as a superb alternative to ceiling speakers when specified as part of a multi-room 'Crestron/AMX/Control4/Sonos' type installation.

These loudspeakers are perfect for demanding applications such as swimming pools, kitchens, gyms, dining rooms, bedrooms etc. Where a certain level of volume and quality is required but not at the expense of the aesthetics of the room.

Wired as a single mono configuration, the 40-30 SL is a highly sensitive speaker and is therefore capable of reproducing very high sound pressure levels from modest (40watt+) amplifiers.

The 40-30 SL can be installed as a stereo speaker or as a single mono speaker



Components Overview:

High Frequency driver:

Dual Ring Radiator diaphragm with highly linear suspension and low loss surrounds for high clarity and clean transient response. Copper caps for better HF extension and lower distortion and wave-guide center plug, copper-clad aluwire

Woofers:

Extra long excursion and Assume Short Circuiting Ring, 4-layer voice coil, anodised aluminium for improved heat dissipation, combined with Distortion Reduced Motor

Crossover:

12 dB/octave sub filter, 6 dB/octave low pass and 12 dB/octave high pass filter

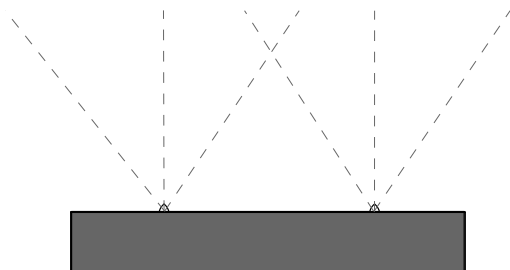

Top view, Controlled Directivity:

Symmetric minimum phase driver configuration for optimal polar response

Specification 40-30 SL Multi Room Speaker

Transducer:

LF-MF 6 x 3 inch cone, Symmetric Phase Aligned
HF 2 x 1 inch Dual Ring Radiator, Symmetric Phase Aligned

Crossover:

Sub Filter Filter 12 dB/octave 70 Hz, Low Pass Filter 6 dB/octave 1000 Hz High Pass
12 dB/octave 4000Hz

Connection:

Single or Bi Amped Gold Plated Push Terminals
Optional Stereo or Mono configuration

Performance:

Operating Range 40 Hz (-3dB) to 40 kHz
Nominal Beamwidth Horizontal 90° Vertical 90°
Axial Sensitivity (whole space SPL) LF/MF-HF (Mono) 93 dB (Stereo) 87 dB
Input Impedance Nominal Minimum (Mono) 4 ohms (Stereo) 6 ohms
Maximum Power Handling 80 Watt
Calculated Axial Output Limit (whole space SPL) Average Peak LF/MF-HF (Mono) 106dB (Stereo) 99dB
Weight 10 kg
Dimensions H: 400 W: 300 D: 67 mm

Finish:

Cabinet: Black, White, RAL, NCS, Tikkurila, Gloss
Screen: Black, White, Pantone, Artcoustic Art Gallery

Specification 40-30 SL Multi Room Speaker

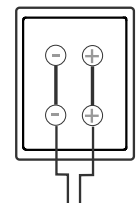
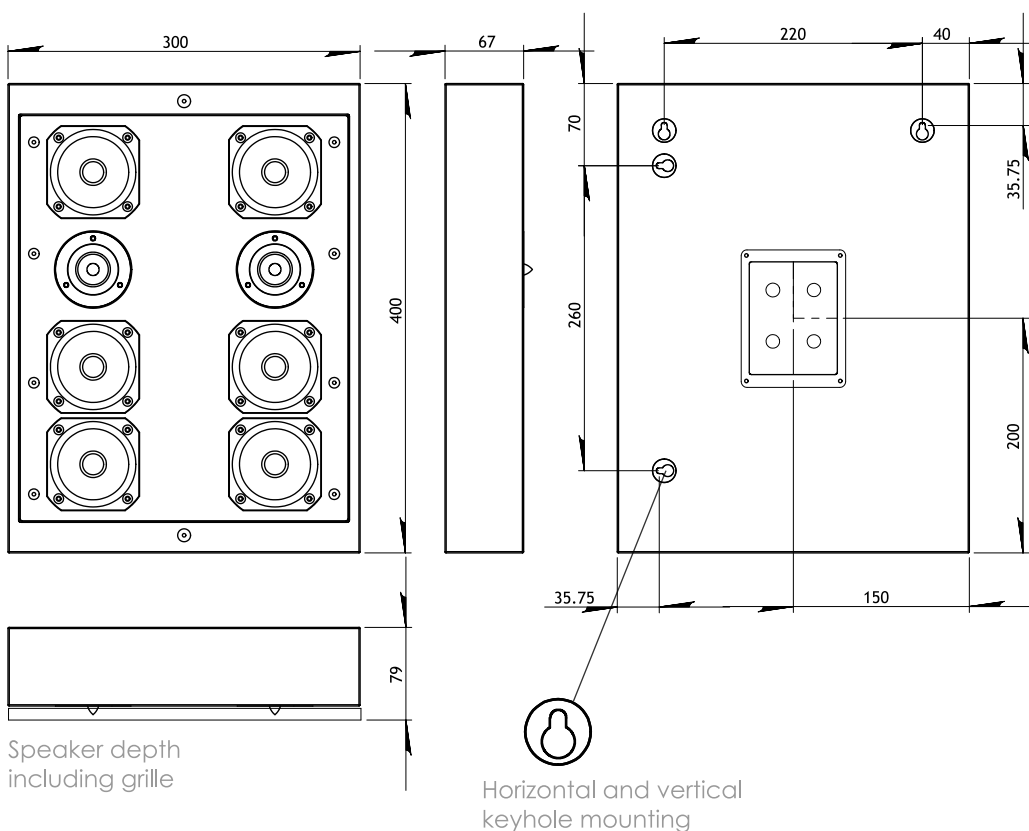

Single speaker (Mono)
configuration 4 ohms

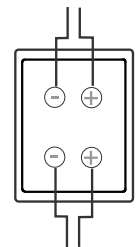

Stereo speaker
configuration 8 ohms

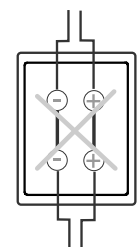

IMPORTANT!
Remove the channel
bridge when wired as
a stereo speaker

Specification 40-30 4-2 SL and 6-3 SL

Specification 40-30 4-2 SL

Transducer:

LF-MF 4 x 3 inch cone, Symmetric Phase Aligned
HF 2 x 1 inch Dual Ring Radiator, Symmetric Phase Aligned

Crossover:

Low Pass Filter 6 dB/octave 1000 Hz High Pass
12 dB/octave 4000Hz

Connection:

Single Amped Gold Plated Push Terminals

Performance:

Operating Range 60 Hz (-3dB) to 40 kHz
Nominal Beamwidth Horizontal 90° Vertical 80°
Axial Sensitivity (whole space SPL) LF/MF-HF 95 dB
Input Impedance Nominal Minimum 4 ohms
Recommended High Pass Filter =>80 Hz, 24 dB/octave
Maximum Power Handling 100 Watt
Calculated Axial Output Limit (whole space SPL)
Average Peak LF/MF-HF 112dB @ 28watt
Weight 5.5 kg
Dimensions H: 400 W: 300 D: 67 mm

Finish:

Cabinet: Black, White, RAL, NCS, Tikkurila, Gloss
Screen: Black, White, Pantone, Artcoustic Art Gallery

Specification 40-30 6-3 SL

Transducer:

LF-MF 6 x 3 inch cone, Symmetric Phase Aligned
HF 3 x 1 inch Dual Ring Radiator, Symmetric Phase Aligned

Crossover:

Low Pass Filter 6 dB/octave 1000 Hz High Pass
12 dB/octave 4000Hz

Connection:

Single Amped Gold Plated Push Terminals

Performance:

Operating Range 65 Hz (-3dB) to 40 kHz
Nominal Beamwidth Horizontal 90° Vertical 75°
Axial Sensitivity (whole space SPL) LF/MF-HF 98 dB
Input Impedance Nominal Minimum 4 ohms
Recommended High Pass Filter =>80 Hz, 24 dB/octave
Maximum Power Handling 100 Watt
Calculated Axial Output Limit (whole space SPL)
Average Peak LF/MF-HF 115dB @ 28watt
Weight 6 kg
Dimensions H: 400 W: 300 D: 67 mm

Finish:

Cabinet: Black, White, RAL, NCS, Tikkurila, Gloss
Screen: Black, White, Pantone, Artcoustic Art Gallery

40-30 4-2 SL Module

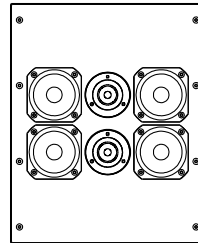

40-30 6-3 SL Module

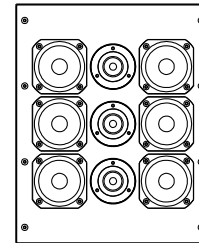

SL Monitors Overview:

Artcoustic's Symmetrically Controlled Beamwidth Array is a ground breaking analogue in-house loudspeaker technology, which enables superior controlled directivity on both vertical and horizontal axis.

With Symmetrically Controlled Beamwidth Array technology, it is possible to achieve very high sound pressure levels without the use of compression horn, very low distortion, very low power consumption and very flat frequency response, but still maintain the desired typical horn qualities, such as directivity and throw.

The SL range is very flexible with compact dimensions and incredible frequency response and very high volumes, it has qualities that make it a truly unique product range.

The ultra slim and lightweight cabinet design makes this series of speakers easy to install into any existing Architecture without sacrificing the aesthetics or the all-important sound quality

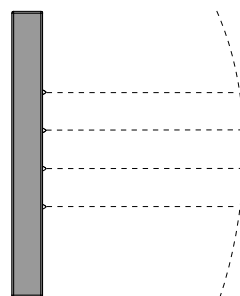

Side view, Symmetrically Controlled Beamwidth Array:

High Sound pressure level at very Low power consumption, combined with controlled vertical directivity

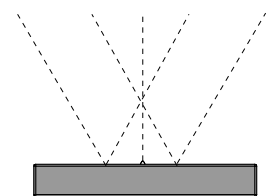

Top view, Controlled Horizontal Directivity:

Symmetric minimum phase driver configuration for optimal polar response